

### Massage Chair MR6000 CALM PLUS

#### Specifications

- Weight: Approx. 222.6 lb
- Power consumption: 140 W

#### Placement & Installation

- Recommended Space  
To position the chair in your home, ensure the doorway is at least 28.5 inches wide for the body and an additional 2.3 inches or more for carrying.

Recommended Space  
31.4 Inches Width

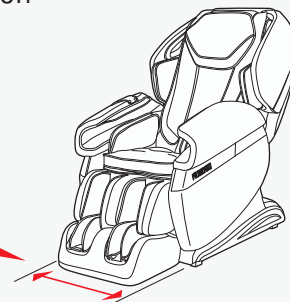

#### Installation

- Installation  
Ensure the chair is installed on a flat surface and allocate sufficient space for reclining. Leave at least 15.7 inches for footrest extension and 13.7 inches for backrest reclining.

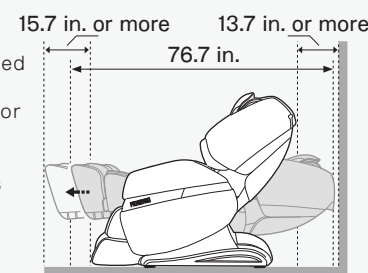

#### Dimensions

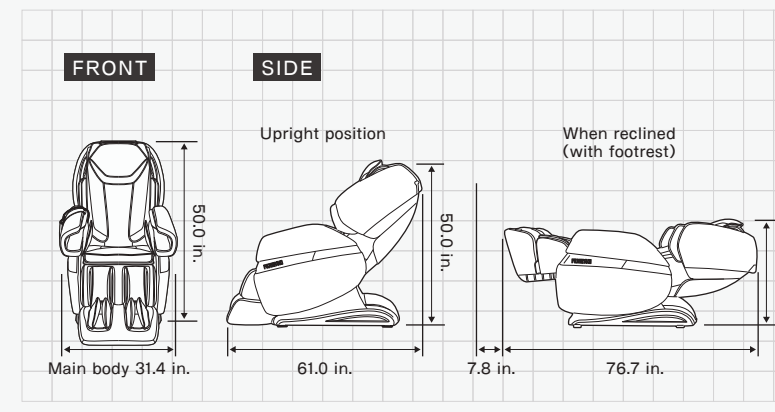

\*All dimensions are approximate.

## FUJIIRYŌKI

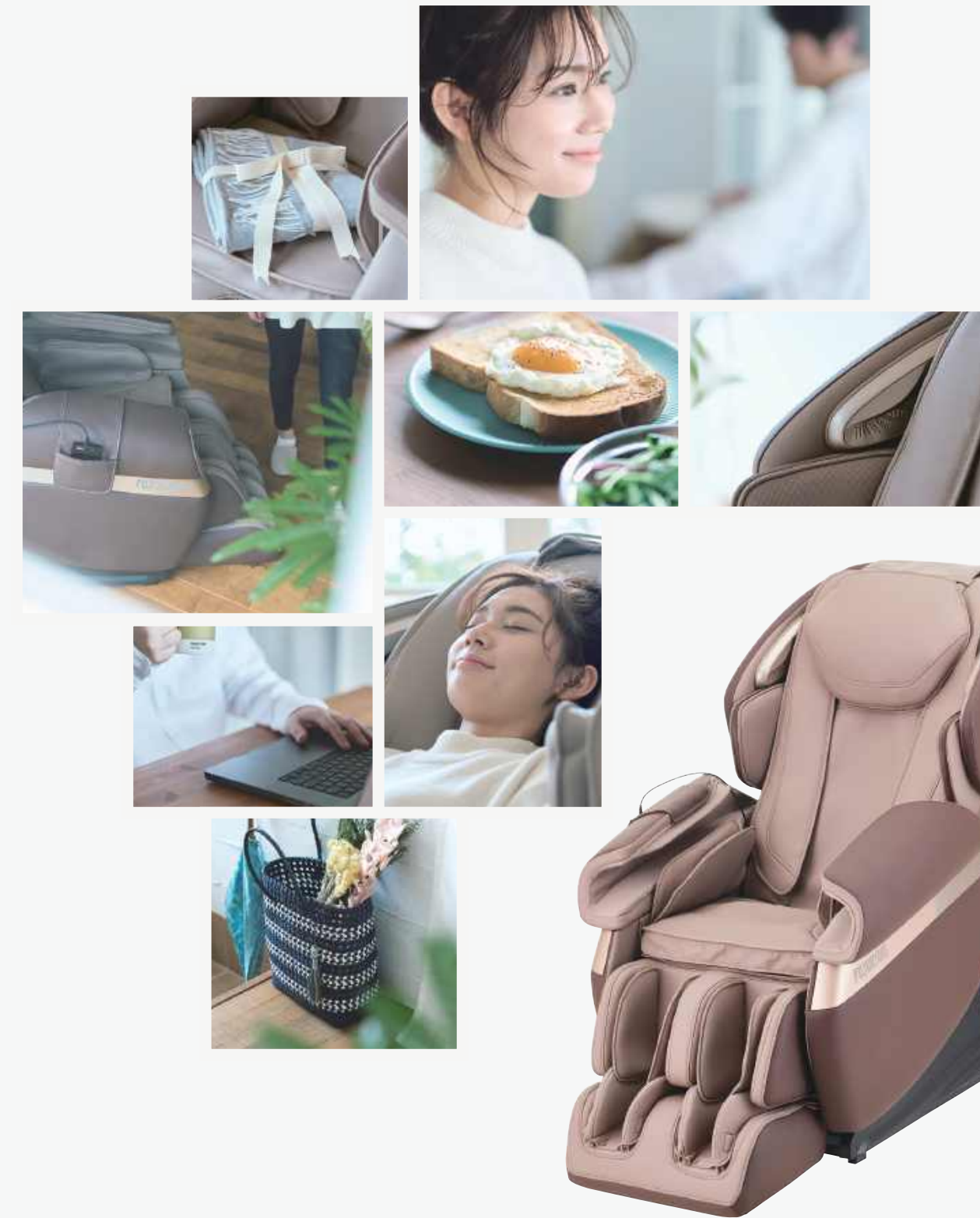

In 1954, the world first mass-produced massage chair was developed by FUJIIRYŌKI.

## FUJIIRYŌKI

FUJIIRYŌKI has sold (shipped) more than 5.16 million massage chairs.\*

The history of massage chairs is the history of Fujiiryoki

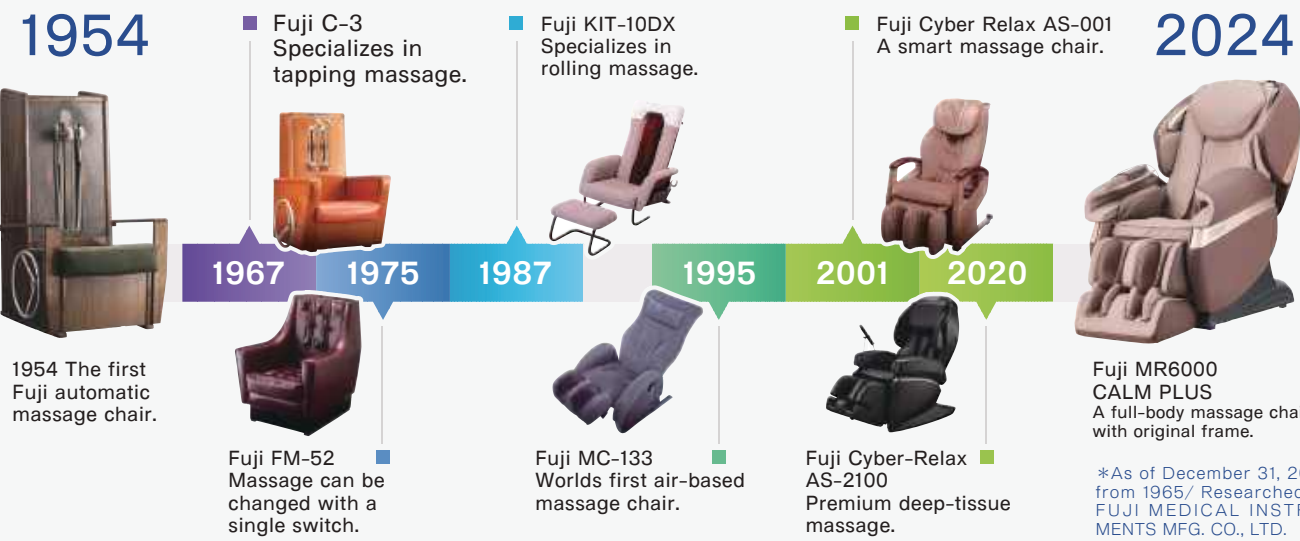

\*As of December 31, 2023 from 1965/ Researched by FUJI MEDICAL INSTRUMENTS MFG. CO., LTD.

The Health and Beauty Manufacturer  
**FUJIIRYŌKI, INC**

371 Van Ness Way Ste 220  
Torrance, CA 90501  
www.fujiiryoki.com

●The design and specifications are subject to change without notice due to product improvement and other factors.  
●Please note that there may be color differences between the print and the actual product.  
●Photos and illustrations are for reference only. ●The contents of this catalogue are as of June 2024.

# MASSAGE CHAIR CALM PLUS+



MASSAGE CHAIR  
**CALM PLUS+**

**Heal Together as a Family**

The CALM PLUS+ massage chair offers a soothing retreat for the whole family. Its versatile features allow you to unwind, recharge, and connect with your loved ones in the comfort of your own home.

Personalized Massage Experience



**Full-Body Coverage  
Flexible Track + 4D**

The chair's flexible track and 4D massage mechanism provide a comprehensive treatment, targeting areas from your shoulders to your feet.



**Unwind and Recharge  
Foot Plus Calf Roller**

Experience the perfect balance of gentle air and soothing rollers, as if you were being pampered by skilled human hands. Feel the tension melt away and enjoy a truly rejuvenating and revitalizing experience.



**Easy to Use  
Touch Screen Remote Control**

Experience the ultimate relaxation with our massage chair's intuitive touchscreen display. With just a simple touch, you can effortlessly customize every aspect of your massage, from the intensity to the technique.

Designed by FUJIIRYOKI in Japan

### Full body massage from neck to hips and feet



#### Upright Position

The backrest is raised for a firm massage from the neck to the shoulders. The massage balls approach the shoulders at a similar angle to human hands, effectively kneading and relaxing stiff shoulders.

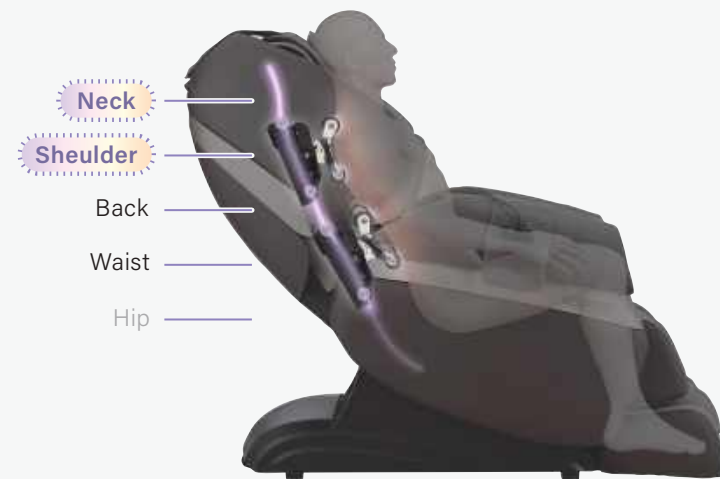

### Flexible SL Track

The unique frame of this massage chair allows the seat to lift up and provide a soothing massage to the buttocks when the backrest is reclined to a certain angle. You can easily adjust the position from a sitting position to a sleeping position. It also features a special flat stretch massage function that stretches your entire body. It massages your neck, back, hips, and thighs, giving you a complete body stretch experience.



#### Reclining Position

Get cozy and relax as your whole-body sinks into the backrest. The advanced frame structure allows for a continuous massage experience from your neck all the way down to your buttocks.



#### Flat Position

Lie down and relax your whole body with the recliner down and the ottoman up. It's the perfect position to unwind and find ultimate comfort.

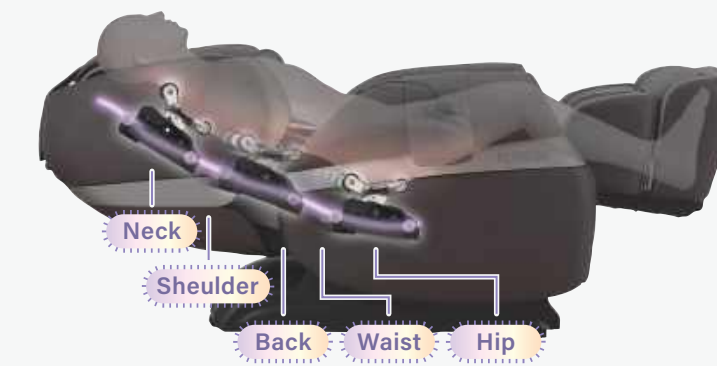

### Triple Calf Massage

This massage chair delivers a soothing massage to your calf muscles through a combination of airbag compression, rubbing airbags, and calf rollers. By employing three distinct massage techniques, it guarantees a comprehensive and invigorating massage session.

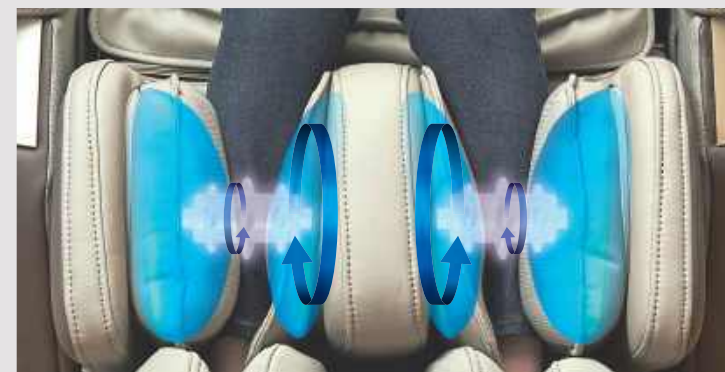

### Foot Double Roller

The top of your foot will be gently massaged by airbags, while the sole of your foot will be stimulated by a series of double rollers. This combination massage helps improve blood circulation and provides a rejuvenating experience.



# Experience a Human-Like Massage with Air 4D + Intelligent Massage Robot

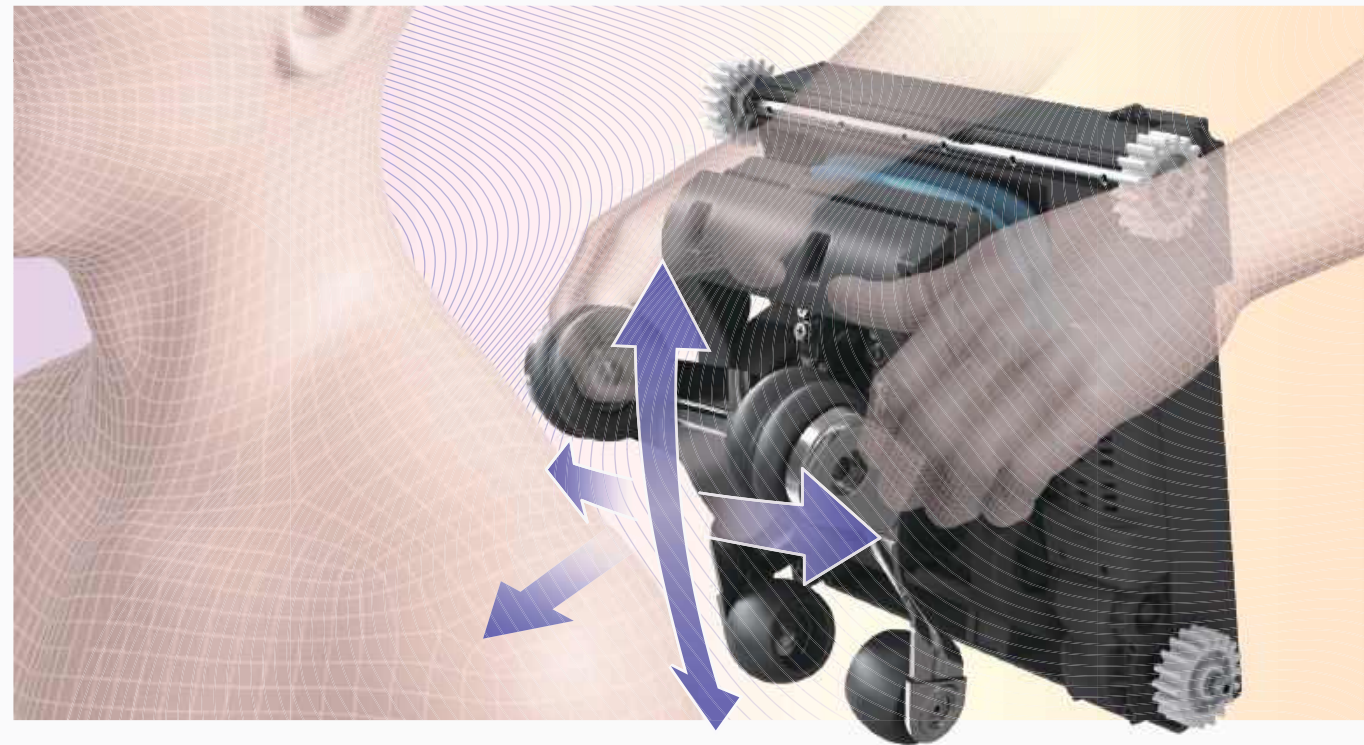

**Air 4D + Intelligent Robot** This advanced mechanism uses air to gently extend the massage ball, creating a softness that mimics the touch of a human hand. Enjoy a combination of 7 different massage techniques and varying speeds to provide a massage that feels just like a professional hand massage.



**Adjust the Intensity**  
The intensity of the massage can be customized to suit your needs. You can fine-tune the strength of the massage balls up to a maximum of 4 levels, with an adjustment range of 3.5 inches.



**Shoulder Position Detection**  
Experience a massage tailored to your unique body shape. Our massage chair incorporates shoulder position detection and program feedback to automatically adjust the massage points based on your height and body shape. This meticulous customization ensures a detailed and personalized massage experience.



**What is 4D?** The 4D feature in a massage robot means it can move right-left, up-down, strong-weak and can also vary its rhythm during the movements, replicating the actions of human hands. Experience the 4D massages in 7 techniques.



<b>Kneading</b> Experience the gentle yet firm kneading motion that loosens stiff muscles.	<b>Rhythmic Kneading</b> Relieve muscle stiffness with the fine and firm kneading motion performed at various speeds.	<b>Wavelet</b> Enjoy a comprehensive and versatile massage experience with the combined motions of kneading and tapping.	<b>Rhythmic Wavelet</b> Experience a dynamic and versatile massage with the integration of kneading and striking at various speeds.
-----------------------------------------------------------------------------------------------	--------------------------------------------------------------------------------------------------------------------------	-----------------------------------------------------------------------------------------------------------------------------	----------------------------------------------------------------------------------------------------------------------------------------

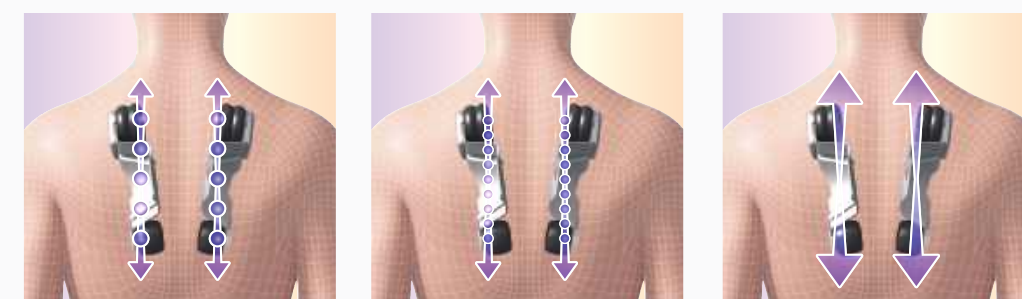

<b>Shiatsu*</b> Gently apply pressure to tight muscles to gradually loosen them and promote relaxation.	<b>Shiatsu* Stretch</b> Perform small incremental movements to push the massage ball into the body, providing a stretch massage.	<b>Rolling</b> Experience a rolling motion along the dorsal muscles, providing a gentle stretch for the back.
------------------------------------------------------------------------------------------------------------	-------------------------------------------------------------------------------------------------------------------------------------	------------------------------------------------------------------------------------------------------------------

\*Shiatsu\* is a massage action in which vertical pressure is applied to muscles with a knead ball.

# Intuitive 5-inch Touch Control with 12 Auto Courses

## Touch Panel

Effortlessly navigate the easy-to-use, full-color 5-inch touch panel controller.



## Release Stretch

Experience a variety of stretching movements through a combination of reclining, airbag, and mechanical functions. Our stretching course combines multiple movements to release unconsciously stiffened muscles.

STRETCH MASSAGE	Yoga Stretch	Combination of multiple stretching movements
	Deep Stretch	Full-body hard stretching to refresh the whole body
	Slow Stretch	Stretch deep into the body with slow movements
FULL BODY	Air Stretch	Stretching course combining airbag and reclining
	Swedish	Full body massage with focus on kneading
	Gentle	Light, rhythmic, slow and fast massage
	Deep Tissue	Full body massage with slow movements focused on shiatsu
FOCUS	Relax	Relaxed movement, recommended before bedtime
	Neck	Course to relieve stiffness and fatigue in the neck and shoulders
	Shoulder	Course to relieve muscle stiffness behind the shoulder blades
	Lumbar	A course to relieve back pain and fatigue
	Glutes	A course that firmly relaxes from the waist to the hips

## Leg Stretch

Enjoy a leg stretch that gently pulls the entire leg downward using our airbag technology, which securely holds the calf and foot.

## Arm Stretch

Secure your arms with airbags and experience a gentle stretch for your entire arm, which tends to be overworked.

## Neck and Back Stretch

Following a deep stretch, our massage hands glide up and down the muscles of your neck and back, offering an extension lift and traction that generates a rejuvenating stretch.

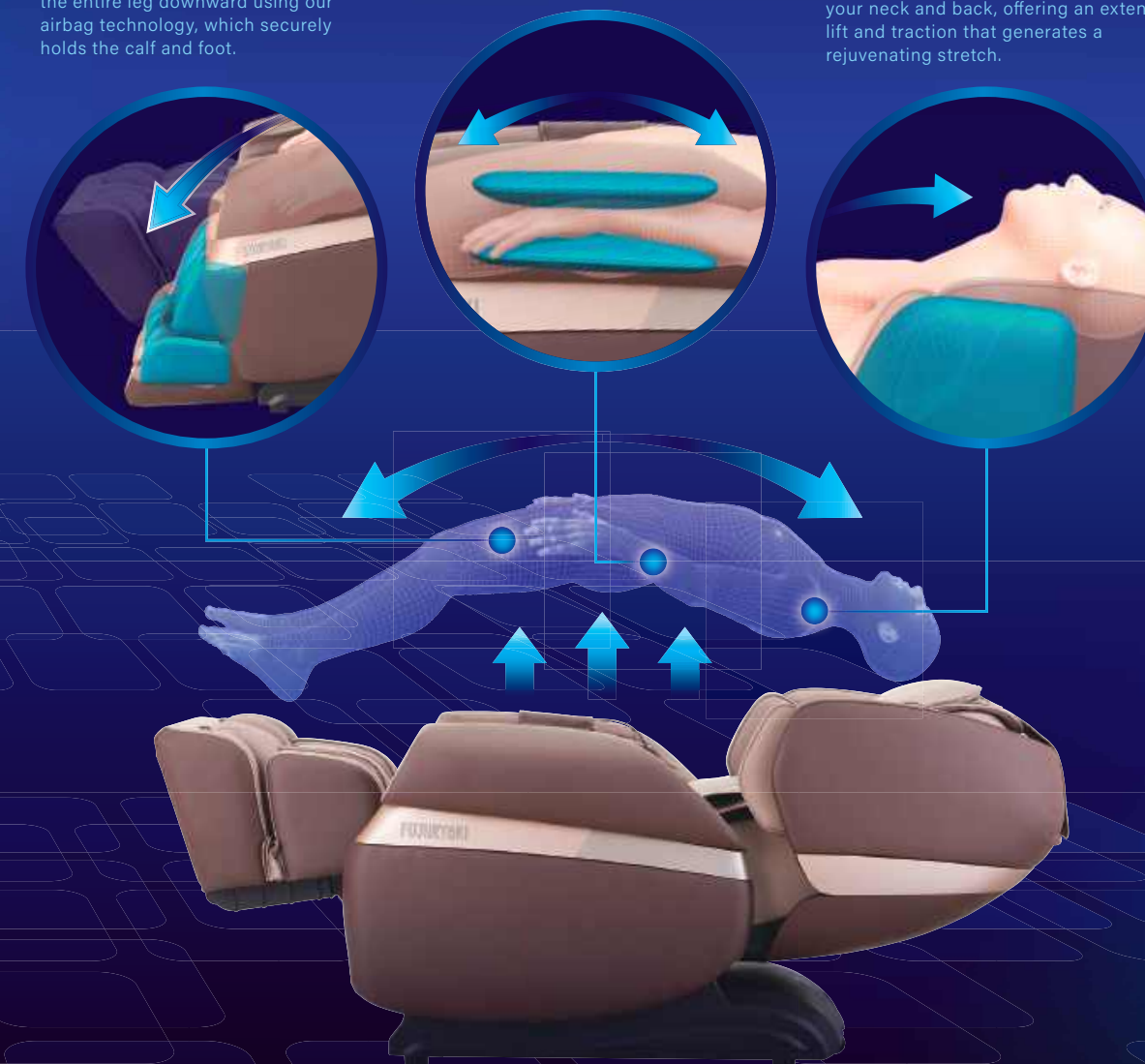

# Surround Yourself with Luxury Comfort at Home



## Full Body Air Massage

Experience ultimate relaxation as large, soft airbags wrap around your shoulders, arms, pelvis, calves, and feet. The airbags compress and release, promoting blood circulation and relieving fatigue. Adjust the intensity to your desired level with 5 customizable settings.

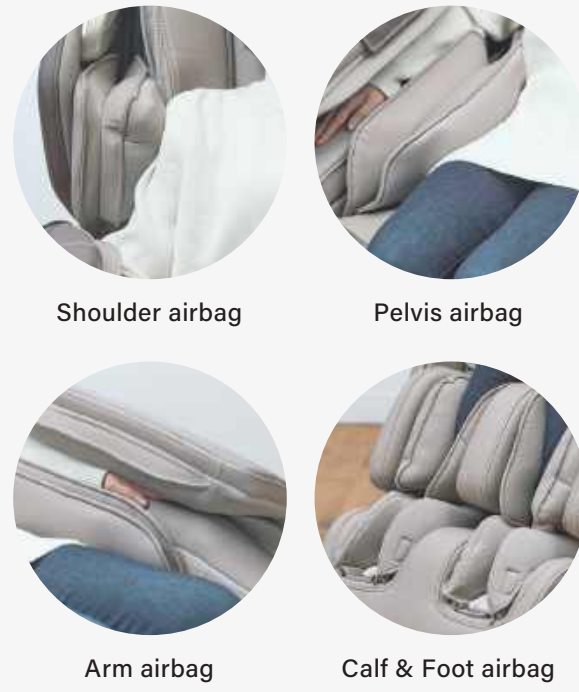

## Soothing Heat

Enjoy a warming sensation as the back pad provides gentle heat to your lower back during the massage. You can also place the heating pad on your stomach area for added warmth.

## Bluetooth Speakers

Immerse yourself in a relaxing ambiance with surround sound speakers. Connect your Bluetooth-enabled devices and enjoy your favorite music while indulging in a massage.

